

Container 1.400 Liter, Typ TCA 14/L

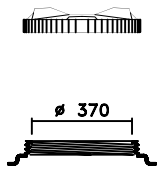

Ø 370

CPF 410
(optional)

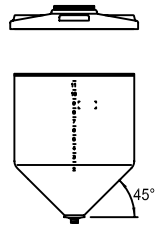

45°

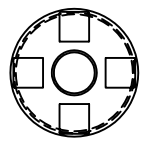

Innenbehälter

Entleerung

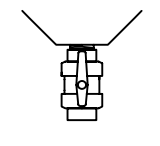

Vertikal

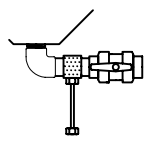

Horizontal

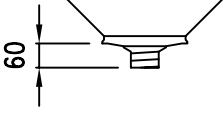
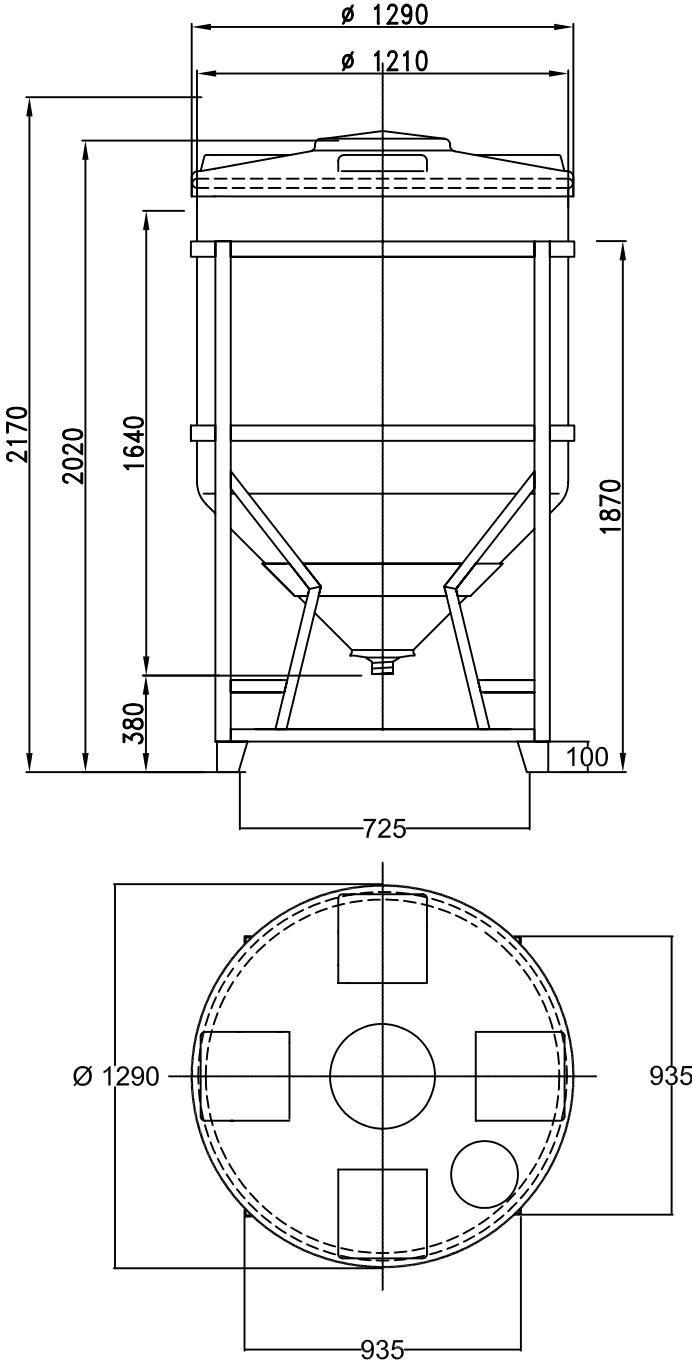

Entleerung : Ø 1" - 1¼" - 1½" - 2" Containerhöhe = 2170mm
 Entleerung : Ø 2½" - 3" - 4" Containerhöhe = 2290mm