

Container 1.500 Liter, Typ TCC 16/L

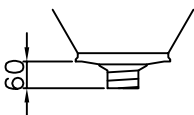
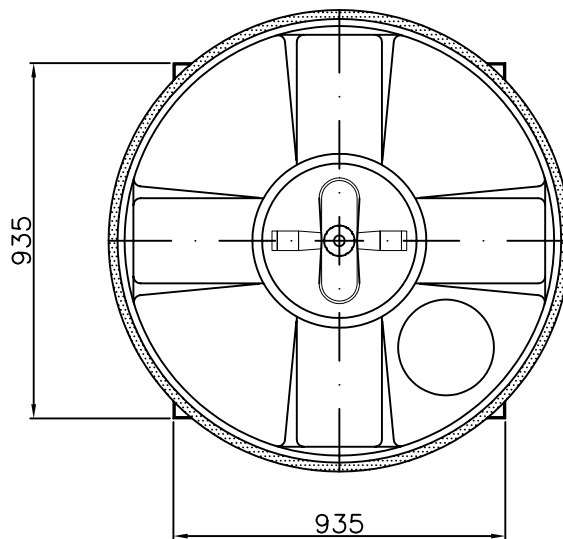
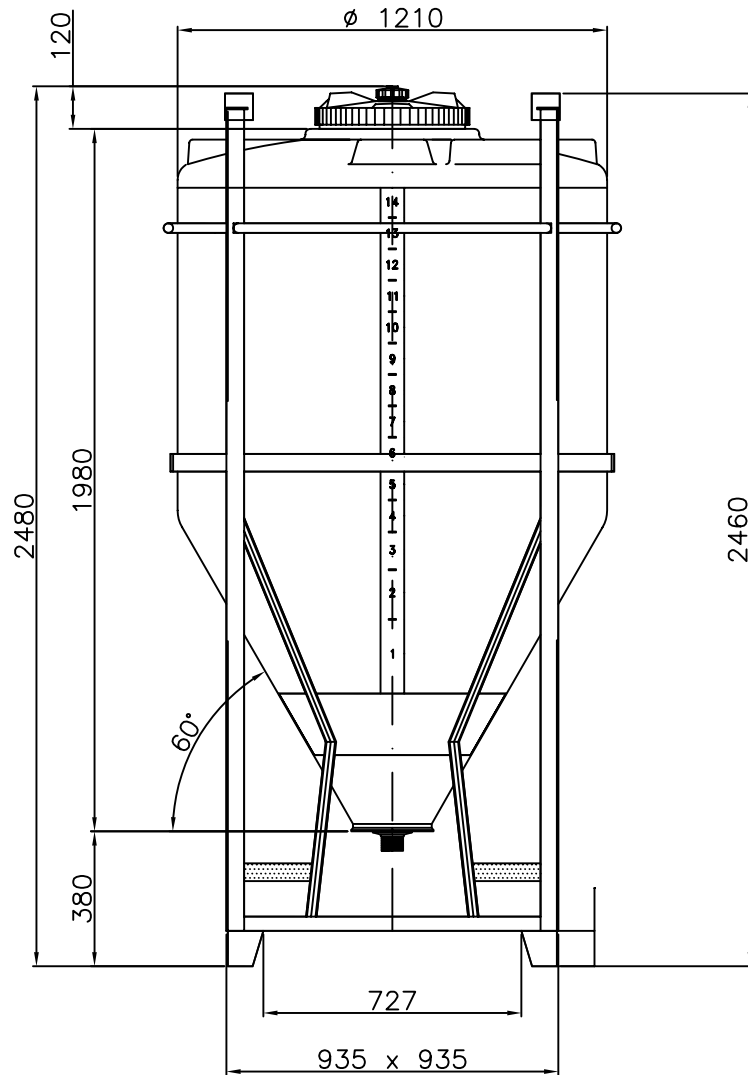

Entleerung: $\varnothing 1'' - 1\frac{1}{4}'' - 1\frac{1}{2}'' - 2''$ Containerhöhe = 2480 mm
Entleerung: $\varnothing 2\frac{1}{2}'' - 3'' - 4''$ Containerhöhe = 2600 mm