

Container 1.280 Liter, Typ TCC 12/L

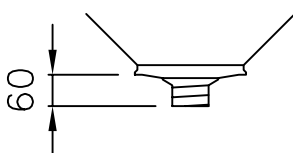
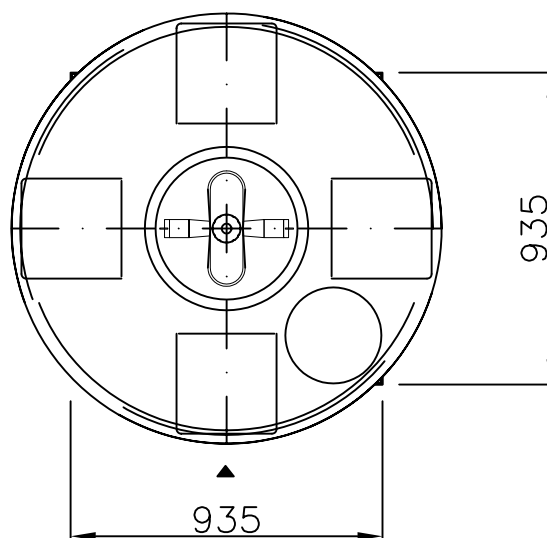
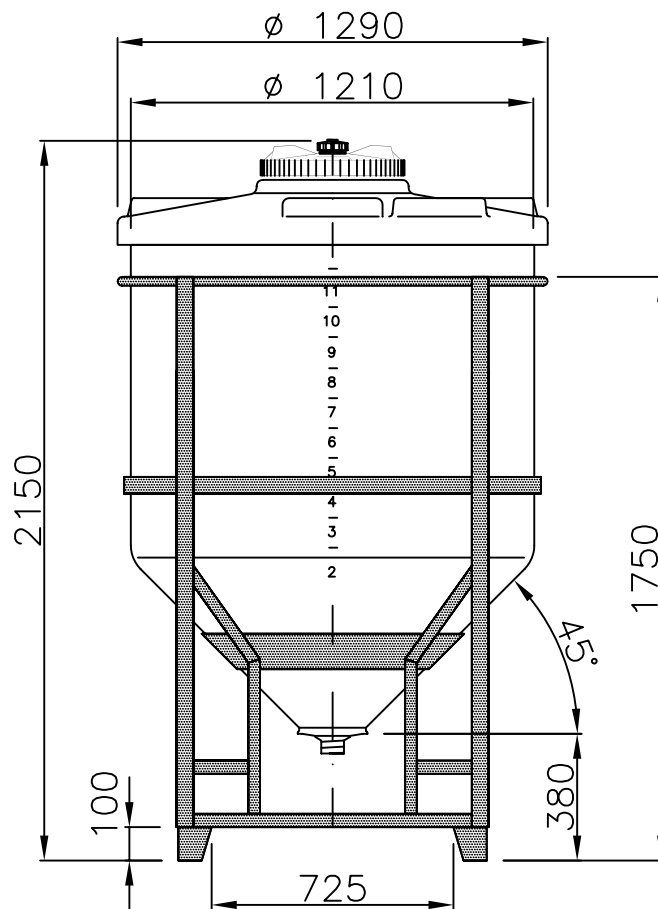

Entleerung : $\varnothing 1'' - 1\frac{1}{4}'' - 1\frac{1}{2}'' - 2''$ Containerhöhe = 2150 mm
 Entleerung $\varnothing 2\frac{1}{2}'' - 3'' - 4''$ Containerhöhe = 2270 mm