

## Container 1.900 Liter, Typ TCO 22/L

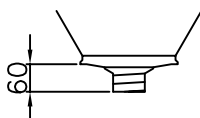
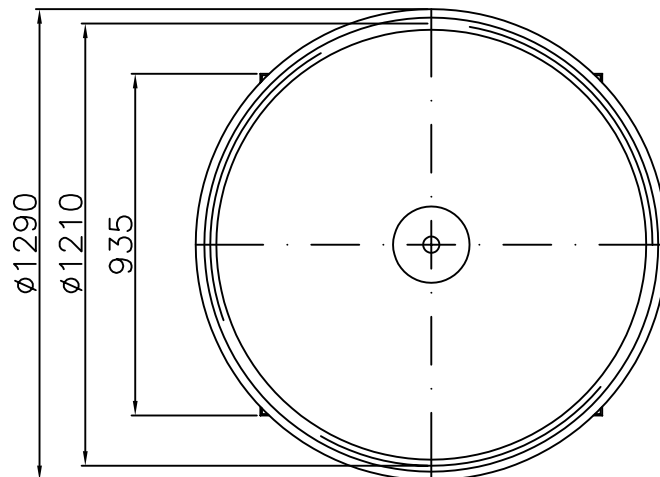
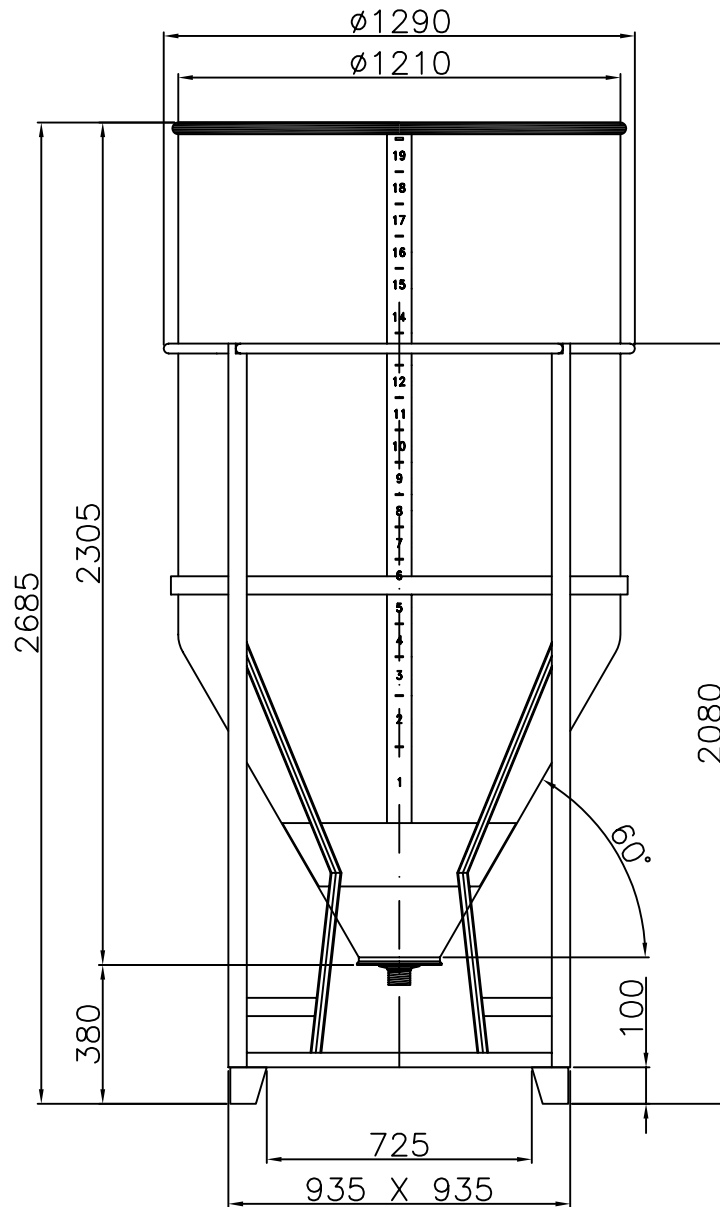

Entleerung:  $\varnothing 1'' - 1\frac{1}{4}'' - 1\frac{1}{2}'' - 2''$  Containerhöhe = 2685 mm  
 Entleerung:  $\varnothing 2\frac{1}{2}'' - 3'' - 4''$  Containerhöhe = 2805 mm