

Container 800 Liter, Typ TCO 8/L

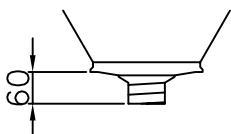
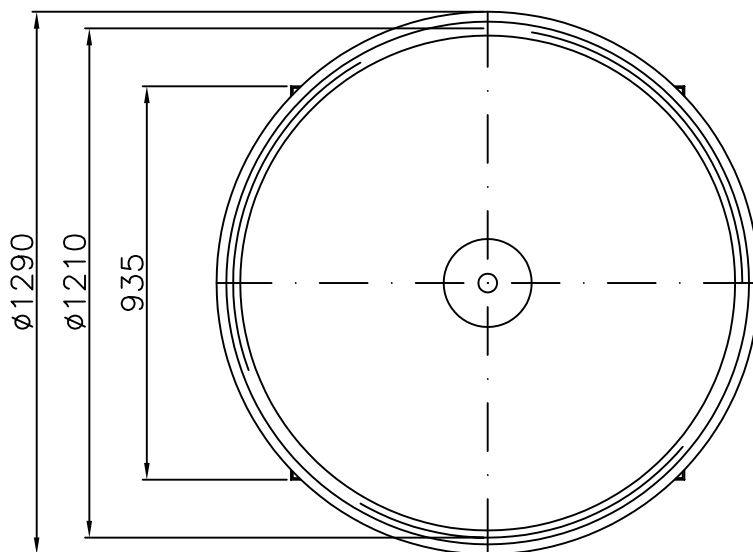
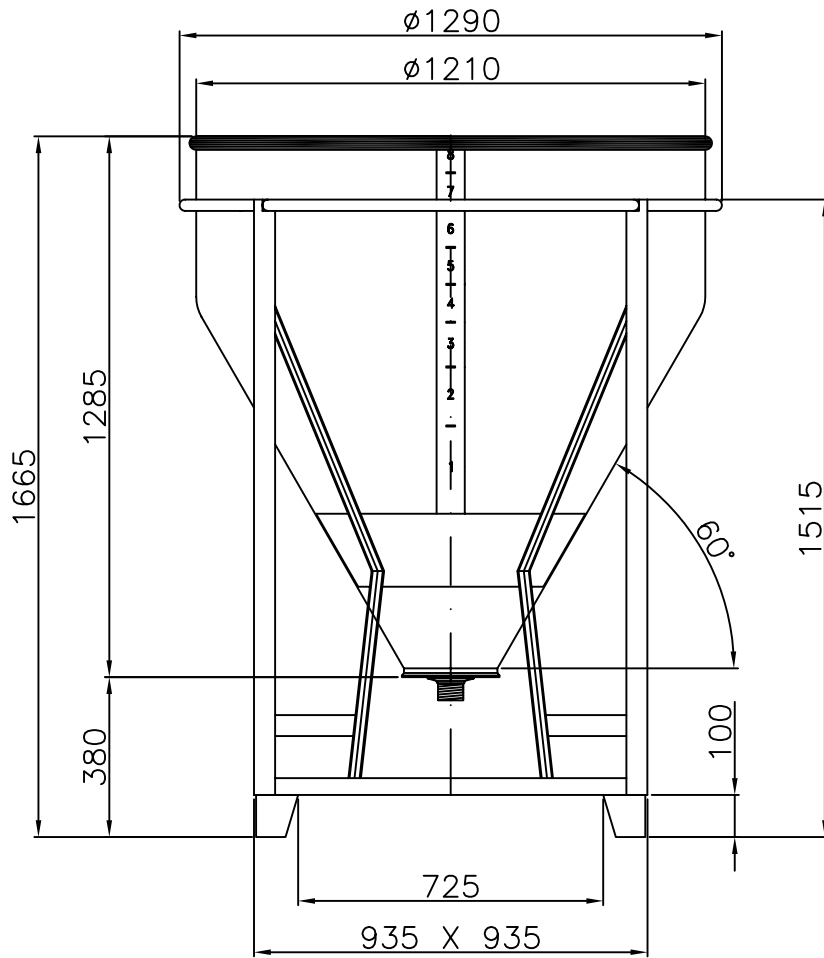

Entleerung: $\varnothing 1'' - 1\frac{1}{4}'' - 1\frac{1}{2}'' - 2''$ Containerhöhe = 1665 mm
 Entleerung: $\varnothing 2\frac{1}{2}'' - 3'' - 4''$ Containerhöhe = 1785 mm