



Container 330 Liter, Typ TC 3/L

Lüfter

∅ 285

CPM-300

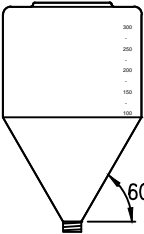

Innenbehälter

Entleerung

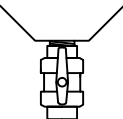

Vertikal

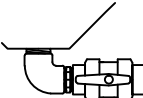

Horizontal

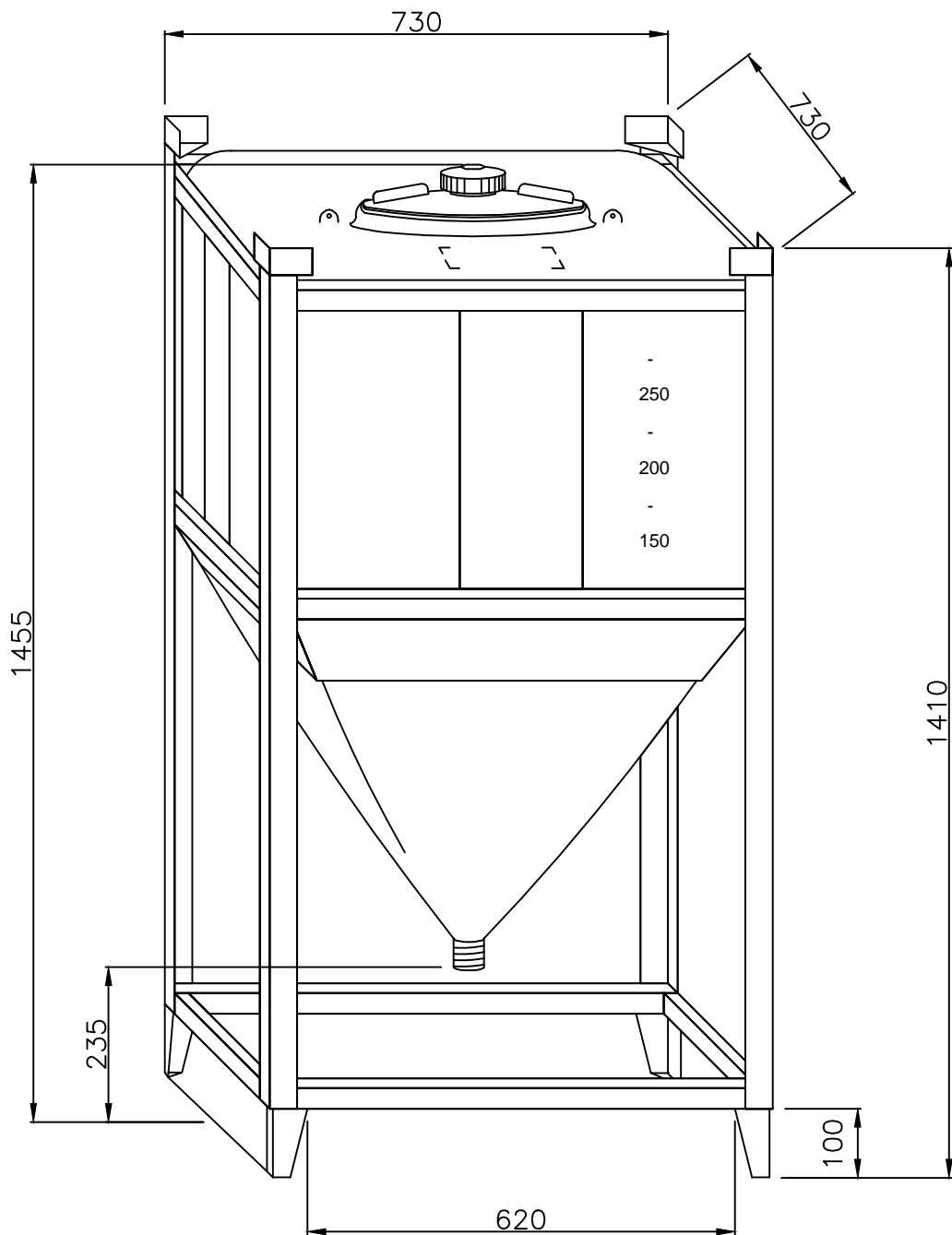

Entleerung : ∅ 1" - 1¼" - 1½" - 2" Containerhöhe = 1410mm

Entleerung : ∅ 2½" - 3" - 4" Containerhöhe = 1620 mm